

ITEM NO.	PART NUMBER	Revision	DESCRIPTION	QTY
1	NDN006	REL-01	Handle Moulding - Tec 6000	1
2	ADD004	REL-02	Heater Housing Assy.	1
3	MDA013	REL-01	Barrel Support Ring	2
4	CMA003	REL-09	Barrel Support	1
5	AED002	REL-01	Spacer/Thermal Fuse Assy.	1
6	AED027	REL-01	Spacer/Thermal Fuse Assy. 240C	1
7	AZZ032	REL-07	Piston Support	1
8	CMA005	REL-04	Tec 6000 Coated Piston	1
9	FOZ001	REL-01	O Ring	1
10	SDC001	REL-01	Piston Plate	1
11	HWZ014	REL-01	Special Washer	1
12	FOZ002	REL-01	O Ring	1
13	NDN001	REL-01	Trigger Moulding	1
14	PA6034	REL-01	Heater Assy. 230V	2
15	PA6035	REL-01	Heater Assy. 120V	2
16	AGD018	REL-01	Sparry Air System Assy	1
17	AGD006	REL-01	6300 Trigger Valve Assy.	1
18	PAP003	REL-01	Urethane Hose 50mm	1
19	PAP004	REL-01	Urethane Hose 75mm	1
20	PAP005	REL-01	PTFE Hose 200mm	1
21	NDR001	REL-03	Nozzle Shroud	1
22	AED012	REL-01	185 Deg. Thermostat Assy.	1
23	AED010	REL-01	195 Deg. Thermostat Assy.	1
24	AED015	REL-01	Thermostat Assy. LowMell	1
25	NDN003	REL-01	Cord Clamp	1
26	PA6060	REL-02	Std. Spray Nozzle Assy - 2mm	1
27	H0188	REL-01	Lens	1
28	NDN005	REL-01	Heavy Duty 6000 Stand	1
29	AED005	REL-01	Earth Wire Assy.	1
30	AED006	REL-01	Earth Wire Assy.	1
31	AED004	REL-01	PCB Assy. 230V	1
32	AED007	REL-01	PCB Assy. 120V	1
33	AGD016	REL-01	Airline Assy. - 3m	1
34	AGD014	REL-01	USA Airline Assy. - 3m	1
35	BG8014	REL-01	1/4" Airline Adaptor	1
36	HWZ030	REL-01	1/4" BSP Washer	1
37	BGZ004	REL-01	Straight Fitting	1
38	FPZ005	REL-01	Compression Spring	1
39	PA6066	REL-01	UK Cordset Assy. 3 Core 3m	1
40	PA6065	REL-01	Euro Cordset Assy. 3 Core 3m	1
41	PA8022	REL-01	USA Cordset Assy. 3 Core 3m	1
42	PA6067	REL-01	110V UK Cordset Assy. 3 Core 3m	1
43	HWZ005	REL-01	6mm Nylon Washer	1
44	HWZ009	REL-01	6mm Steel Washer	2
45	HWZ013	REL-01	6mm Spring Washer	1
46	HSZ048	REL-01	Shoulder Ball	1
47	PA1042	REL-01	4BA Spring Washer	2
48	HSZ006	REL-01	Screw M5 x 12 Slot Cheese Head	4
49	HSZ020	REL-01	1/4" x 1/2" Screw	1
50	HSZ049	REL-01	3.5 x 10mm Screw	2
51	HSZ060	REL-01	Screw 3.5 x 19 Pozi Pan	1
52	HSZ015	REL-01	Screw 10-32 x 3/16" SKT-SET	1
53	HSZ013	REL-01	6-32 UNC x 1/4" Screw	3
54	PA1032	REL-01	Screw 4BA x 1/4" Pozi Pan	1
55	PA3045	REL-01	4 x 12mm Pan Head Screw	6

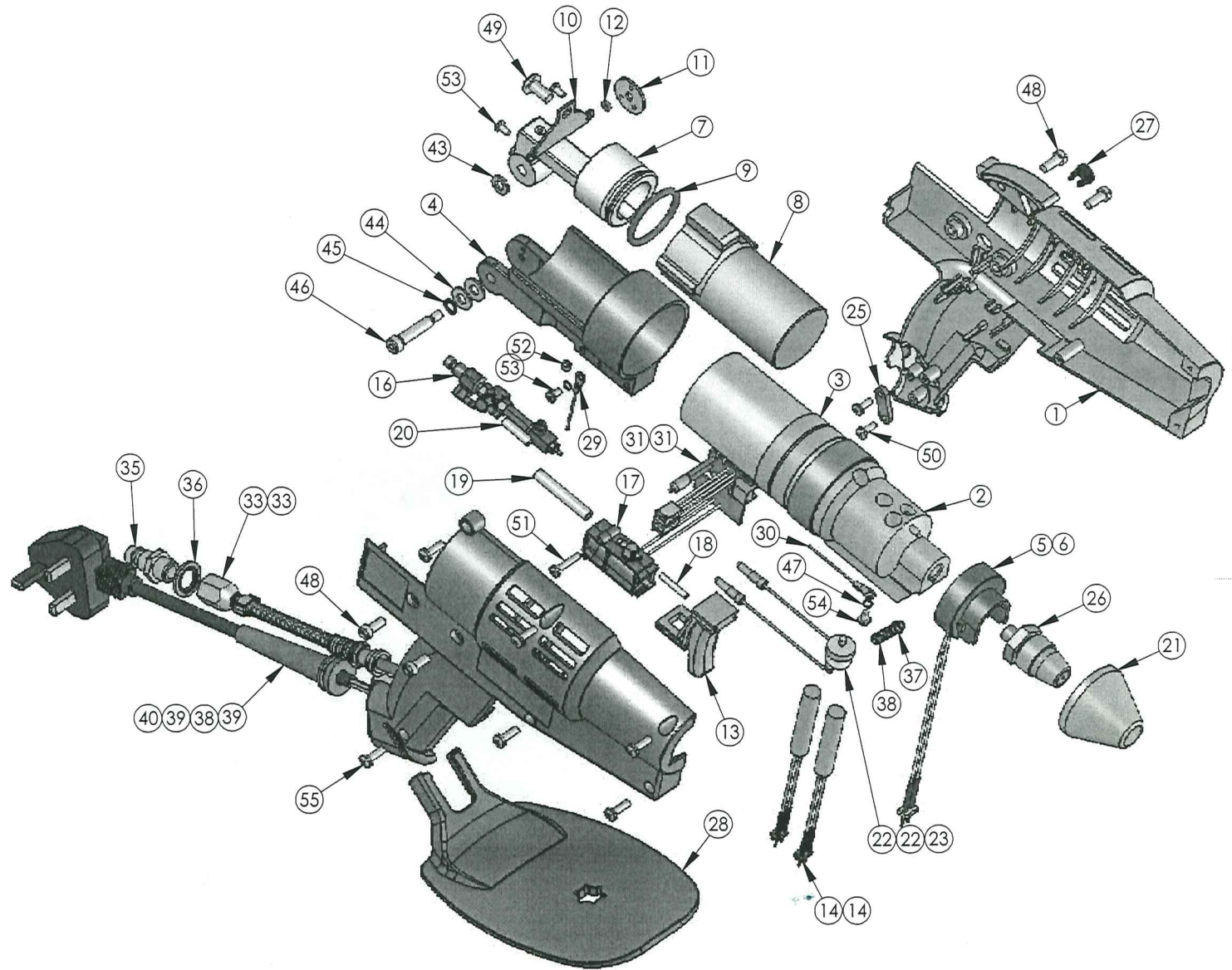

THIS DRAWING AND THE INFORMATION IT CONTAINS IS THE PROPERTY OF POWER ADHESIVES AND IS CONFIDENTIAL. IT MUST NOT BE REPRODUCED EITHER WHOLLY OR IN PART. ALL RIGHTS IN RESPECT OF PATENTS, DESIGNS AND COPYRIGHTS ARE RESERVED.

MATERIAL	DRAWN	Steve	DIMENSIONS ARE IN MM UNLESS OTHERWISE STATED	TOLERANCES UNLESS OTHERWISE STATED	SCALE 1:2.5
FINISH	DATE		THIRD ANGLE	WHOLE NUMBERS ±0.5mm 1 DECIMAL PLACE ±0.3mm 2 DECIMAL PLACE ±0.1mm	SHEET 1 OF 1
COLOUR	ECN No.		TITLE		
NOTES	Tec 6300				
From Serial Number 21685 -	DWG. No. A3 Tec 6300 REVISION REL-01				

273